

## LOUIS MOINET “MAGISTRALIS”

*A hundred-year-old movement, an authentic 2000-year-old piece of the moon, a box that works like a musical instrument, the famous 1848 *Traité d’Horlogerie* (Watchmaking Treatise) – dreams are ever present in the history of this watch.*

Magistralis is an extraordinary watch representing the expert craftsmanship of the time-honoured art of Haute Horlogerie. It is one of a kind, unlike any other, and will never be repeated.

### **The movement**

The movement was created a hundred years ago. Designed in the Vallée de Joux, it was made in Geneva and bears the *Poinçon de Genève* quality hallmark. It beats at 18,000 vibrations per hour and features a (double-bladed) self-compensating balance and a flame-blued Breguet balance spring. Its flat-polished moustache lever escapement is hand chamfered and mounted on an endstone.



### **The chronograph**

The single-button column-wheel chronograph (6 columns) has a spring-assisted lever. The instantaneous jumping minute hand, a very distinctive mechanism, operates by means of a cam. The function of the cam is to load the minute lever by means of constant friction, thereby stabilising regulator operation (by avoiding loss of amplitude) when the chronograph function is activated. This technique is no longer used now, given the complexity of its entirely manual fine-tuning.

### **The striking mechanism**

The striking mechanism comprises two hammers that sound the hours, quarter-hours and minutes, as well as an “all or nothing” lever. The mechanism for activating the striking mechanism is operated by pressing a lever, so as to facilitate handling of the repeater slide, which is always a delicate operation on traditional watches.

The making of a striking mechanism will always remain a manual operation that simply cannot be industrialised. Indeed, the extreme accuracy of the adjustments required for this complication can neither be done by machine nor measured; they truly do come from the watchmaker’s hand, ear and heart. For this reason, two identical striking mechanisms will sound different, precisely because they are adjusted by hand. The creation of a striking mechanism quite obviously requires all the experience of a skilful and knowledgeable master-watchmaker.

### **The perpetual calendar**

The perpetual calendar function displays the day, date and month over four years. Its unique feature is its small size, as the perpetual date mechanisms of the period were usually much larger.

All of the steel parts of the bridges are polished with a tin block to achieve a perfect polish and cold-work the material so as to eliminate any cracks and thus protect it from oxidation with no need for any additional treatment. That is why these century-old steel parts are still as perfect as ever.

### **The moon phase**

Louis Moinet is presenting a world first, a lunar phase complication with real pieces of the moon! These pieces are from a lunar meteorite that was ejected from the moon 2,000 years ago. The meteorite, which has been authenticated by the University of California, actually added to our knowledge of lunar geology, since it came from a place that the Apollo missions did not visit. Moonstone is an extremely rare material that is even more expensive than gold and platinum combined.



### The case

The case is made of 5N and 3N 18-carat rose gold. Its brand-signature design stands out especially for its crown guard (patent pending) and its chronograph button guard at 12 o'clock. The 90-part case is extremely complex to make. It features a pressure-controlled striking-mechanism lever, which makes the slide easier to manipulate. The various correctors are marked with the Louis Moinet symbols so their purpose is obvious.

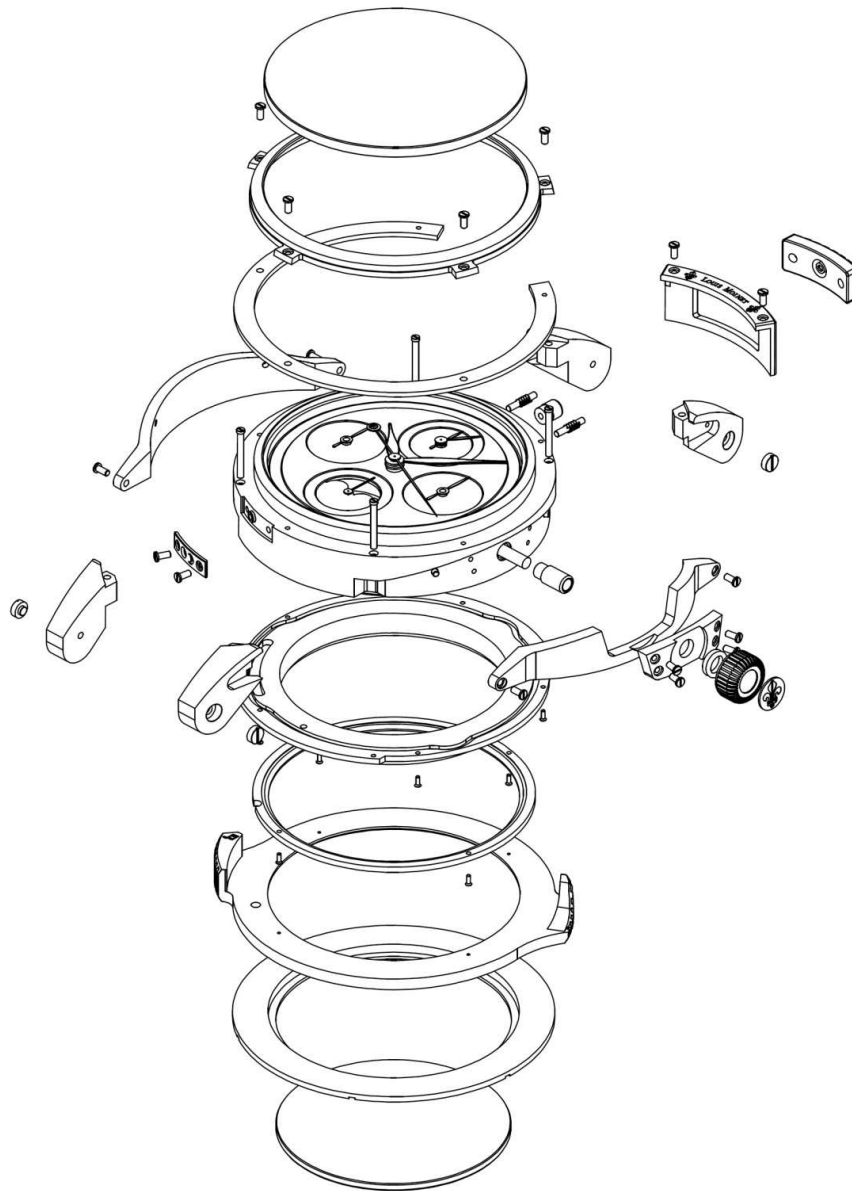

### The dial

The dial is adorned with the “Côtes du Jura”<sup>®</sup> motif, an exclusive creation from the Ateliers Louis Moinet. The four counters are hollowed and their “old rose” shade ensures excellent readability of the indications provided by the century-old flame-blued steel hands.

### The box

An extraordinary watch deserves an extraordinary box! The box is entirely hand-crafted from curly maple by luthier Claude Bourquard, from the Jura. Claude has a thorough knowledge of resonance, acquired by making guitars and violins of the highest quality by hand. He has used this knowledge to design a true musical instrument using the watch support. Once the striking mechanism has been activated, the instrument amplifies its sound so the tone can be fully appreciated. This instrument is made of curly maple and varnished spruce, and Claude jealously safeguards the secrets of its manufacture, which make it a unique object.



### **The 1848 *Traité d'Horlogerie***

An original of the *Traité d'Horlogerie* by Louis Moinet is also included in the box. This is the second edition, dated 1856. This book has the reputation of being the most beautiful of its century, and describes the best watchmaking techniques. It is illustrated by dozens of pages of watch mechanisms hand-drawn by Louis Moinet.

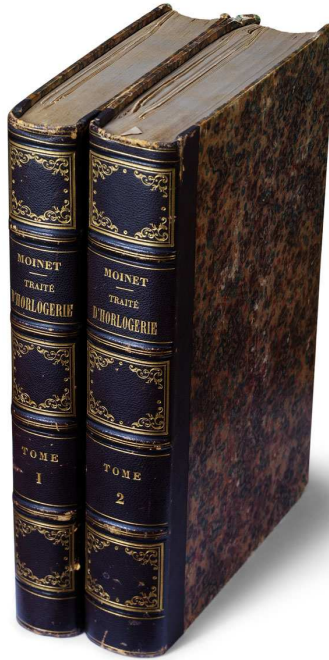

So the circle is complete, and everything surrounding this creation is truly extraordinary...

### **MAGISTRALIS, Limited Edition of 1**

LM-15.65.50/50

5N and 3N 18-carat rose gold

Black dial

### **PRICE**

CHF 1,000,000.00 (one million swiss francs)

### **DELIVERY**

SUMMER 2008